



RF Repeater Module TCM 110

User Manual V1.5
March 2006

Revision History

The following major modifications and improvements have been made to the initial version of the document (TCM 110 User Manual V1.0):

Version	Subject (major changes since last version)
1.1	Current consumption corrected, approval requirements modified, minor corrections
1.2	2.3 Telegram timing corrected
1.3	Declaration of conformity added
1.4	FCC/IC Approval Requirements added
1.5	Correction in current consumption.

**Published by EnOcean GmbH,
Kolpingring 18a, 82041 Oberhaching**

© EnOcean GmbH
All Rights Reserved

Important!

This information describes the type of component and shall not be considered as assured characteristics. No responsibility is assumed for possible omissions or inaccuracies. Circuitry and specifications are subject to change without notice. For the latest product specifications, refer to the EnOcean website: <http://www.enocean.com>.

As far as patents or other rights of third parties are concerned, liability is only assumed for components, not for applications, processes and circuits implemented within components or assemblies.

EnOcean does not assume responsibility for use of devices described and limits its liability to the replacement of devices determined to be defective due to workmanship. Devices or systems containing RF components must meet the essential requirements of the local legal authorities.

EnOcean GmbH does not recommend the use of its products in life support applications and will not knowingly sell its products for use in such applications unless it receives an adequate "products liability indemnification insurance agreement".

Components of the modules are considered and should be disposed of as hazardous waste. Local government regulations are to be observed.

Packing: Please use the recycling operators known to you. By agreement we will take packing material back if it is sorted. You must bear the costs of transport. For packing material that is returned to us unsorted or that we are not obliged to accept, we shall have to invoice you for any costs incurred.

Table of Contents

1. GENERAL DESCRIPTION	4
1.1 Features Overview	4
1.2 Physical Dimensions	4
1.3 Environmental Conditions	5
1.4 Ordering Information	5
2. FUNCTIONAL DESCRIPTION	6
2.1 Block Diagram	6
2.2 Pin Description	6
2.3 One-level Repeater	7
2.4 Received Signal Strength Indicator (RSSI)	8
3. APPLICATIONS INFORMATION	9
3.1 Module Mounting	9
3.2 Antenna Mounting	9
3.3 Transmission Range	10
3.4 Power Supply Requirements	11
3.5 Approval Requirements	11
4. DECLARATION OF CONFORMITY	14

1. GENERAL DESCRIPTION

The repeater module TCM 110 of EnOcean enables the implementation of highly efficient RF repeaters for EnOcean radio systems.

A typical application is the easy to install local optimization of system radio coverage to ensure good radio reception behind shadowing objects or in recesses behind room corners for example.

The TCM 110 transceiver module serves the 868 MHz air interface protocol of EnOcean. It receives all signals of the EnOcean radio transmitters (based on e.g. modules PTM 100, STM 100) and sends refreshed signals to any EnOcean radio receiver (based on e.g. receiver modules RCM 110, RCM 120, TCM 120).

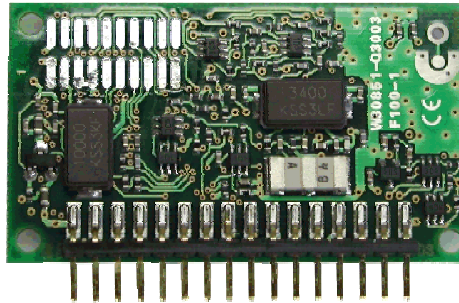

Figure 1: Repeater module TCM 110

1.1 Features Overview

Frequency / modulation type / transmission power:..... 868.3 MHz / ASK / max. 10 mW
Data rate (transmitter) / channel bandwidth (receiver):..... 120 kbps / 280 kHz
Transmission range: 300 m free field
Signal repeater functionality:..... one level repeating of received EnOcean telegrams
Power supply voltage: 5V +10%/-5%
Power supply operation current (receive): typ. 33mA, max. 40 mA
Power supply operation current (receive+transmit): max. 55 mA
Transmitting indication output (LED): 20 mA max., approx. 3 x 2 ms within 50 ms

1.2 Physical Dimensions

Antenna:..... No antenna installed, 9 cm whip antenna or external antenna mountable
Dimensions of PCB: 24.0 x 42.0 x 5 mm (without wiring pins)
Connector: 16 pins, grid 2.0 mm (4.0 mm in length, □ 0.5 mm)

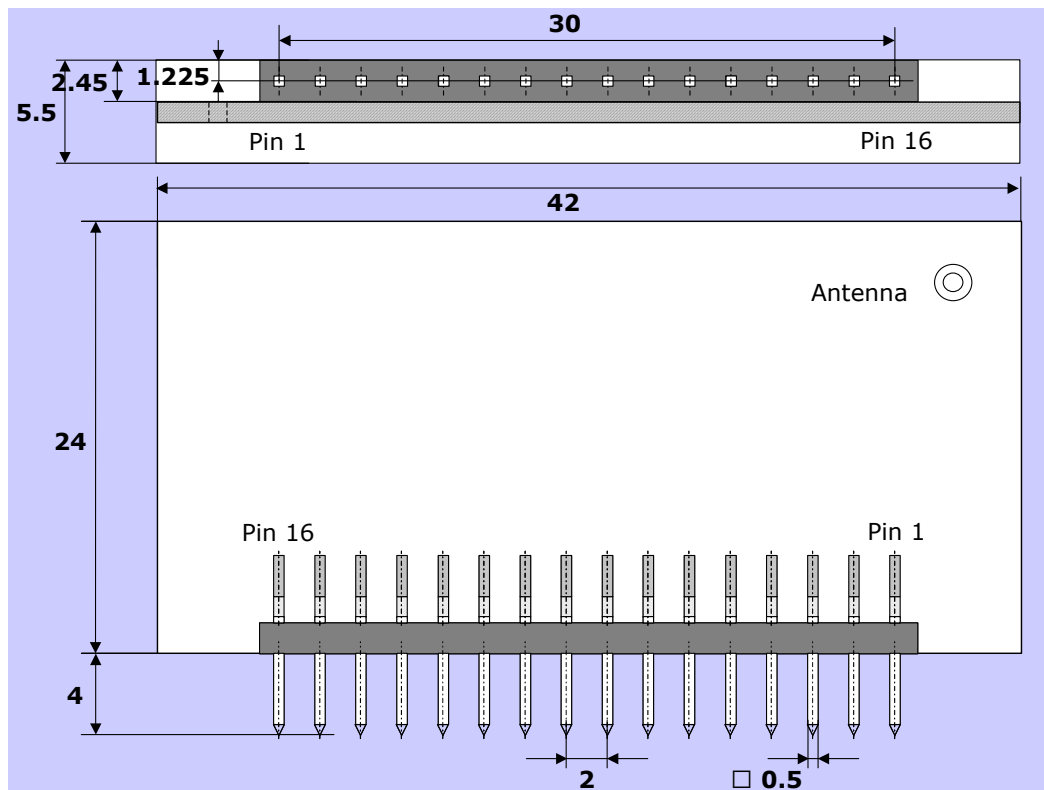

Figure 2: TCM 110 package outline

1.3 Environmental Conditions

Operating temperature: -25 up to +65 °C

Storage temperature: -40 up to +85 °C, +85 up to +100 °C for 1h max.

Humidity: 0 % to 95 % r.h.

1.4 Ordering Information

Type	EnOcean Ordering Code
TCM 110	S3003-K110

2. FUNCTIONAL DESCRIPTION

2.1 Block Diagram

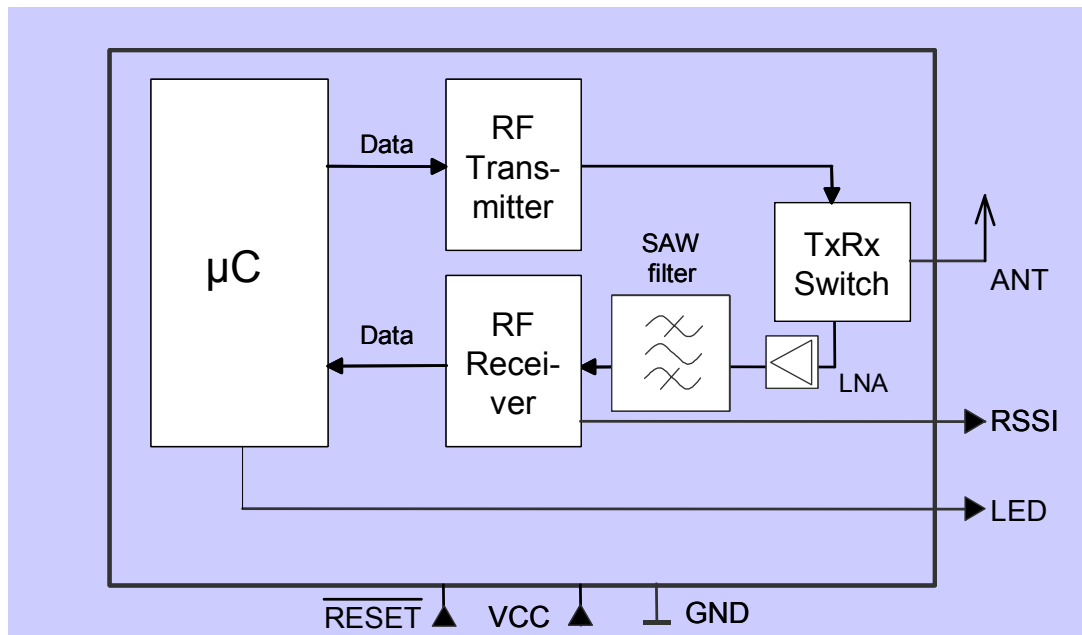

Figure 3: Block diagram of TCM 110

2.2 Pin Description

Pin No.	Symbol	Function	Operational characteristics
1, 16	GND	Ground connection	
2	RESET	External reset signal	May be left open for normal operation
12	LED	Transmission indicator	20 mA max., approx. 3x2 ms within 50 ms
14	RSSI	Indication output of received signal strength (peak detection)	Source impedance app. 20 KΩ
15	VCC	Power supply	5 V DC +10%/-5%, 55 mA max. (without LED current)
Other			Leave open

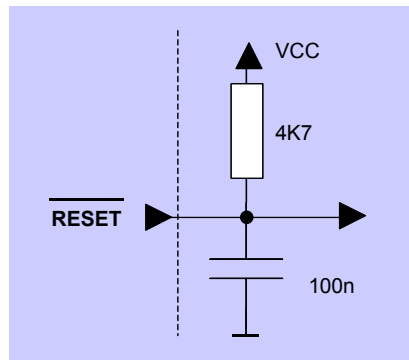

Figure 4: Equivalent schematics for /RESET

2.3 One-level Repeater

The TCM 110 module implements a one-level repeater for EnOcean radio telegrams. As soon as a new RF telegram is received, it is interpreted and checked. If it is a valid and original (not yet repeated) telegram, the telegram is repeated after a random delay. The repeated telegram is marked as "repeated". Please note that configuration telegrams are not repeated.

The repeated signal consists of three subtelegrams as the original telegram.

Repeater transmit timing:

Delay between received telegram and 1st subtelegram: $1 \text{ ms} + n \times 1 \text{ ms}$ (integer n : $0 \leq n \leq 3$)

Delay between 1st and 2nd subtelegram: $6 \text{ ms} + n \times 1 \text{ ms}$ (integer n : $0 \leq n \leq 3$)

Delay between 2nd and 3rd subtelegram: $18 \text{ ms} + n \times 1 \text{ ms}$ (integer n : $0 \leq n \leq 11$)

2.4 Received Signal Strength Indicator (RSSI)

The RSSI output of the TCM 110 module is useful for transmission range tests. By indicating the strength of an incoming RF signal, this output allows the assessment of RF link quality and transmission range. The RSSI pin output voltage is typically 0.9 V with no RF signal, rising to typically 2.6 V at maximum signal. The external loading should be kept to a minimum since the RSSI output source impedance is around 20 k Ω . The following shows a typical RSSI characteristic:

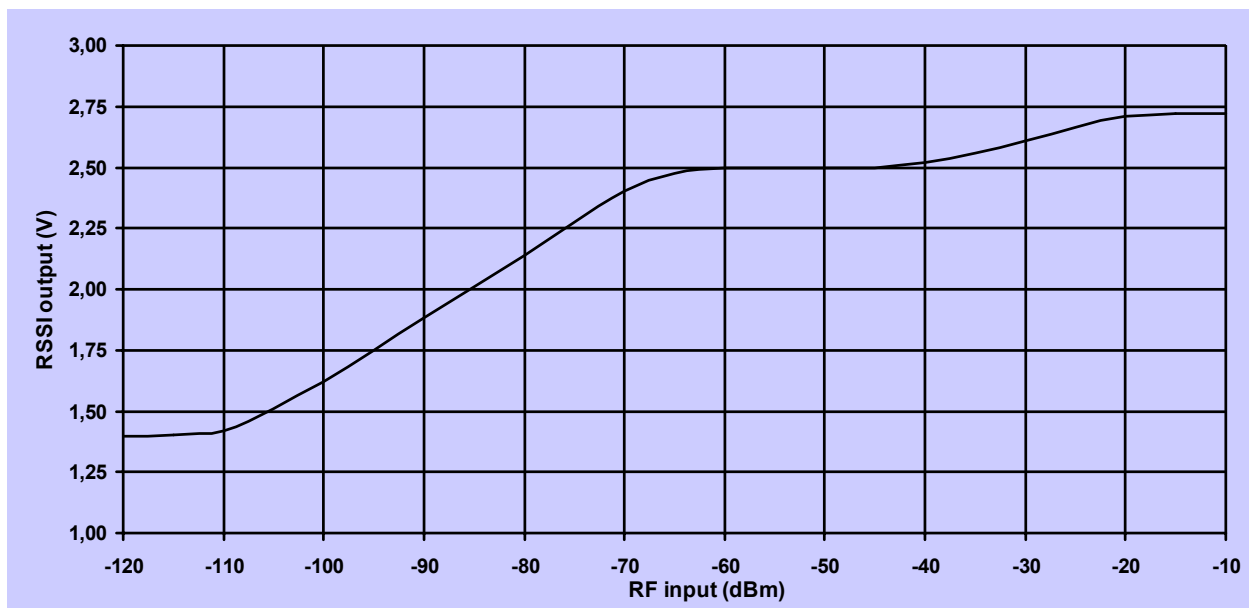

Figure 5: RSSI output characteristics

3. APPLICATIONS INFORMATION

3.1 Module Mounting

The modules may be mounted in vertical or horizontal position to the motherboard of the application device (load module). In a vertical position, the module pins can be directly connected to the motherboard through suitable PCB holes. Optionally or for horizontal mounting, suitable female strip connectors for through-hole or SMD assembling are available and are supplied ready to the required contact number (e.g. type BLY from Fischer Elektronik). Additional module fixing may be necessary in rough environments.

The following features have to be available on the motherboard:

- Power supply for the repeater module (GND, VCC)
- Optional: connection to RSSI and LED output signal

3.2 Antenna Mounting

Positioning and choice of receiver and transmitter antennas are the most important factors in determining system transmission range. The TCM 110 modules are supplied without antenna. For standard applications, the use of a whip antenna is recommended (87 mm/ 0.14 mm² Cu-wire). This antenna enables a very compact unit with good radio reception characteristics. For mounting the antenna, the following notes should be considered to optimize the system performance:

a) Mounting a 1/4-wave whip antenna:

For good receive/transmit performance, great care must be taken about the space immediately around the antenna since this has a strong influence on screening and detuning the antenna. The antenna should be drawn out as far as possible and must never be cut off. Primarily, the far end of the wire should be mounted as far away as possible from all metal parts, PCB strip lines and fast logic components (e.g. microprocessors). To avoid radio frequency hash from the motherboard, which desensitizes the unit, PCB strip lines on the motherboard should be designed as short as possible, and using a PCB ground plane layer is also recommended.

Note that 868 MHz whip antennas do not show any directional effects under free-field radio-wave propagation conditions (spot-wise radiator).

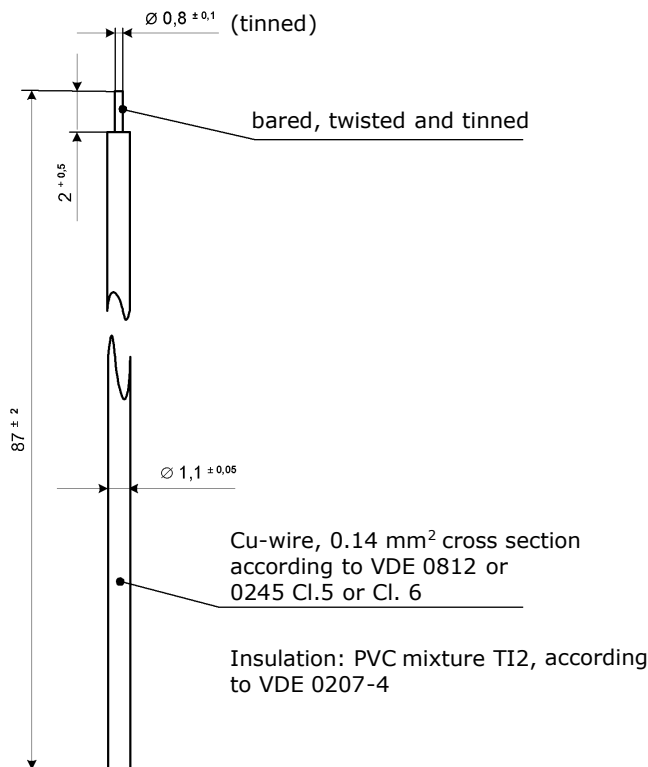

Figure 6: Specification of whip antenna

b) Mounting an external antenna:

For mounting the device at bad RF locations (e.g. within a metal cabinet), an external antenna must be used. The external antenna can be connected to the equipment by a 50Ω coax feeder.

3.3 Transmission Range

The main factors that influence the system transmission range are type and location of the antennas of the receiver and the transmitter, type of terrain and degree of obstruction of the link path, sources of interference affecting the receiver, and "dead" spots caused by signal reflections from nearby conductive objects. Since the expected transmission range strongly depends on this system conditions, range tests should categorically be performed before notification of a particular range that will be attainable by a particular application.

The following figures for expected transmission range are considered by using a PTM, a STM or a TCM radio transmitter device and the RCM or the TCM radio receiver device with preinstalled whip antenna and may be used as a rough guide only:

- **Line-of-sight connections:** Typically 30m range in corridors, up to 100m in halls
- **Plasterboard walls / dry wood:** Typically 30m range, through max. 5 walls
- **Brick walls / aerated concrete:** Typically 20m range, through max. 3 walls
- **Ferroconcrete walls / ceilings:** Typically 10m range, through max. 1 ceiling
- **Fire-safety walls, elevator shafts, staircases and supply areas should be considered as screening.**

The angle at which the transmitted signal hits the wall is very important. The effective wall thickness – and with it the signal attenuation – varies according to this angle. Signals should be transmitted as directly as possible through the wall. Wall niches should be avoided. Other factors restricting transmission range:

- **Switch mounted on metal surfaces (up to 30% loss of transmission range)**
- **Hollow lightweight walls filled with insulating wool on metal foil**
- **False ceilings with panels of metal or carbon fiber**
- **Lead glass or glass with metal coating, steel furniture**

The distance between EnOcean receivers and other transmitting devices such as computers, audio and video equipment that also emit high-frequency signals should be at least 0.5m

Please note for use in the US and in Canada: In the US, 868 MHz frequency range is used by Trunk Radio. Since a reduction of transmission range is to be expected near a trunk radio station, range tests at the system's target location should categorically be performed before notification of a particular range in the US and in Canada!

3.4 Power Supply Requirements

The ripple-to-noise ratio on the supply rail should be below 10mVp-p to avoid problems. If the quality of the supply is in doubt, it is recommended that a 10uF low-ESR tantalum or similar capacitor be added between the module supply pin (Vcc) and ground, together with a 6.8 Ω series feed resistor between the Vcc pin and the supply rail

3.5 CE Approval Requirements

The modules bear the EC conformity marking CE and conforms to the R&TTE EU-directive on radio equipment. The assembly conforms to the European and national requirements of electromagnetic compatibility. The conformity has been proven and the according documentation has been deposited at EnOcean. The modules can be operated without notification and free of charge in the area of the European Union, in Switzerland, in Cyprus, in Czech, in Estonia, in Hungary, in Latvia, in Lithuania, in Malta, in Poland, in Romania and in Slovenia. The following provisos apply:

- EnOcean RF modules must not be modified or used outside their specification limits.
- EnOcean RF modules may only be used to transfer digital or digitized data. Analog speech and/or music are not permitted.
- The final product incorporating EnOcean RF modules must itself meet the essential requirement of the R&TTE Directive and a CE marking must be affixed on the final product and on the sales packaging each. Operating instructions containing a Declaration of Conformity has to be attached.
- If transmitters are used according to the regulations of the 868.3 MHz band, a so-called "Duty Cycle" of 1% per hour for each transmitter must not be

exceeded. As the TCM 110 is a repeater, it has to be ensured by the installer that this limit is not exceeded. Calculations showed that a repeater in a building with 200 transmitters still uses less than 1/10 of the permitted duty cycle.

Please note that a full radio approval is needed if the TCM 110 is used with another than the 1/4-wave whip antenna described in chapter 3.2a!

3.6 FCC Approval Requirements

Because of the very low radiated field strength on average, the 868.3 MHz EnOcean radio technology can be approved in the USA and in Canada. If the TCM is operated in compliance with the following requirements, a finished good containing this radio will comply with Part 15 of the FCC Rules and with RSS-210 of Industry Canada. **Please be aware of the possibility of reduced transmission range when using an EnOcean 868 MHz system near a US trunk radio station!**

Because dedicated timing limit conditions are claimed, no TCM module approval is possible in general. **The finished good has to be approved by a notified body for operating free of charge in the area of the United States of America ("FCC approval") and in Canada ("IC approval").**

3.6.1 FCC Part 15 field strength limits

The limit for 868.3 MHz according to FCC15.231 is 82 dBuV/m at 3 m distance AVERAGE. The reduced limit for periodic transmissions according to FCC15.231e is 4 dB less. Considering the calculated peak to average factor of the EnOcean transmitters, there should be no problem with respect to FCC part 15 field strength limit values. The AVERAGE radiated output power of TCM 1xx with 1/4-wave whip antenna can be calculated as follows, considering the worst case telegram length (4BS of STM100):

- On pulse train is min. 24 ms, max 63.3 ms, depending on software. The length of one packet is 1.2 ms. Within a packet the duty cycle is ~50%, ~ 0.6 ms. So we have in worst case 4 pulse trains within 100 ms with together 12 packets with 0.6 ms TX-time.
- Added we have a TX-time $12 \cdot 0.6$ ms within 100ms, this is a duty cycle of 7.2%. So we calculate the average value $20 \cdot \log(7.2/100) = -22.8$ dB. The measured radiated output power of TCM1xx is 100.8 dBuV/m at 3m distance PEAK (Source: Test report by CeTeCom). The calculated **AVERAGE radiated output power is $100.8 \text{ dBuV/m} - 22.8 \text{ dB} = 78.0 \text{ dBuV/m}$ at 3m distance and **4 dB lower than the limit of 82 dBuV/m for 868.3 MHz according to FCC15.231.****
- A test report containing the TCM measurement details with 1/4-wave whip antenna is available from EnOcean on request.

3.6.2 FCC/IC operational and timing requirements

Because of the very low average to peak factor, the (corrected) field strengths of EnOcean transmitters meet the 15.231 conditions for manually operated transmitters and the lower field strength limit values for intentional radiators operated at a periodic rate. In addition to the field strength limits, the following timing conditions have to be met with respect to 15.231:

- **Intentional radiators operated at a periodic rate:**

Periodic transmissions of EnOcean modules at regular predetermined intervals are allowed with respect to 15.231e, if the silent period between transmissions is in no case less than 10 seconds.

- **Manually operated transmitters, Presence signals:**

- Periodic transmissions at regular predetermined intervals are permitted under the conditions of 15.231e only. However, polling or supervision transmissions, including data, to determine system integrity of transmitters used in security or safety applications (e.g. presence signals of STM100 and STM250 based applications) are allowed if the total duration of transmissions does not exceed more than two seconds per hour for each transmitter. There is no limit on the number of individual transmissions, provided the **total transmission time does not exceed two seconds per hour**.
- This means that the following system conditions must be met to comply with Part 15 requirements under conditions of excessive data rates: **It must be ensured that the TCM radio module does not transmit data more than 1058 times per hour (manually operated telegrams and presence telegrams)**. For this timing calculation the worst case of STM100 packet length of 1.2 ms, a tolerance of 5% in packet length, a 50% on average packet Ton/Toff ratio and all 3 redundant packets are considered.

4. DECLARATION OF CONFORMITY



EnOcean GmbH
Kolpingring 18a
D 82041 Oberhaching
www.enocean.com

Declaration of Conformity



We: EnOcean GmbH
Kolpingring 18a
D 82041 Oberhaching
Germany

Declare: under our sole responsibility that the following labeled products:

Transmitter: PTM100, STM100, STM250, PTM200

Receiver: RCM110, RCM120, RCM121

Transceiver: TCM110, TCM120

to which this declaration relates, are, when used according to specification, in conformity with the technical requirements of the standards and the provisions of the essential requirements of the Directives detailed below.

Directives: Electromagnetic Compatibility Directive 89/336/EC

Radio and Telecommunications Terminal Equipment Directive R&TTE 1999/5/EC

Standards: ETSI EN 301 489-1: 2001-09, ETSI EN 301 489-3: 2001-11 (class 2)

ETSI EN 61000-6-2: 2002-08

ETSI EN 300 220-3: 2000-09

Place of issue: Oberhaching
Quality Manager:
Dr. Matthias Heiden
Signature:

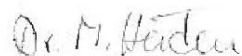

Date of issue: 13. May 2005
General Manager:
Markus Brehler
Signature:

