



Radio Magnet Contact STM 250

User Manual V1.5
April 2006

Revision History

The following major modifications and improvements have been made to the first version of this document (V1.0):

Version	Major Changes
V1.1	<ul style="list-style-type: none"> • Chapter 1.5 "Physical Dimensions of Magnet Housing" added • Chapter 2.6 "Learning" fully revised and renamed • Chapter 2.3 "Radio Telegram" revised • Chapter 3.2 "Recommendations for Magnet Positioning" revised
V1.2	<ul style="list-style-type: none"> • Chapter 2.5: The bits LRN and STATE in DATABYTE_3 have been defined in final: (LRN="0": "LRN-pushbutton pressed" and STATE="0": "No magnet presence")
V1.3	<ul style="list-style-type: none"> • ESD protection: Note added that STM250 is qualified for the use within building automation & installation, not for industrial applications (chapter 1.2) • Switch over time defined to $\geq 80\text{ms}$ (chapter 1.3) • Cyclic presence signal time defined to 5-30 minutes, typ. 15 min (chapter 1.3) • Update of Solar Energy Balance Calculation (chapter 1.3 and 2.2) • Energy storage: Notes added concerning Goldcap configuration and concerning reduced component life time at continuously operation temperatures higher than 50°C (chapter 2.2) • Mounting note added, that the receiver unit should not be placed at the same plane as the STM250 when STM250 is mounted on a metal surface (chapter 3.1)
V1.4	<ul style="list-style-type: none"> • Water protection class reduced to IP40, indoor use only (chapter 1.6) • Transmission range described in more detail (chapter 3.3) • FCC/IC Approval Requirements added (chapter 3.6) • US version of Evaluation Kit added (chapter 4.1)
V1.5	<ul style="list-style-type: none"> • Sub-telegram timing corrected

Published by EnOcean GmbH, Kolpingring 18a, 82041 Oberhaching, Germany
www.enocean.com, info@enocean.com, phone ++49 (89) 6734 6890

© EnOcean GmbH, all Rights Reserved

Important!

This information describes the type of component and shall not be considered as assured characteristics. No responsibility is assumed for possible omissions or inaccuracies. Circuitry and specifications are subject to change without notice. For the latest product specifications, refer to the EnOcean website: <http://www.enocean.com>.

As far as patents or other rights of third parties are concerned, liability is only assumed for devices, not for the described applications, processes and circuits.

EnOcean does not assume responsibility for use of devices described and limits its liability to the replacement of devices determined to be defective due to workmanship. Devices or systems containing RF components must meet the essential requirements of the local legal authorities.

The devices must not be used in any relation with equipment that supports, directly or indirectly, human health or life or with applications that can result in danger for people, animals or real value.

Components of the devices are considered and should be disposed of as hazardous waste. Local government regulations are to be observed.

Packing: Please use the recycling operators known to you. By agreement we will take packing material back if it is sorted. You must bear the costs of transport. For packing material that is returned to us unsorted or that we are not obliged to accept, we shall have to invoice you for any costs incurred.

Table of Contents

1. GENERAL DESCRIPTION	4
1.1 Basic Functionality	4
1.2 Typical Applications	5
1.3 Features Overview	5
1.4 Dimensions of Reed Contact Unit	6
1.5 Dimensions of Magnet Housing	8
1.6 Environmental Conditions	9
1.7 Ordering Information	9
2. FUNCTIONAL DESCRIPTION	10
2.1 Block Diagram	10
2.2 Solar Energy Balance Calculation	12
2.3 STM 250 Radio Telegram	15
2.5 Serial Data Communication via Receiver Device RCM 120	17
2.6 Learn Pushbutton – Learning of STM 250 to a Receiver	18
3. APPLICATIONS INFORMATION	19
3.1 Unit Mounting	19
3.2 Recommendations for Magnet Positioning	19
3.3 Transmission Range	21
3.4 CE Approval Requirements	21
3.5 FCC/IC Approval Requirements	22
4. TOOLS	24
4.1 Evaluation Kit EVA 100/105	24
4.2 Field Intensity Meter EPM 100	24
5. DECLARATION OF CONFORMITY	25

1. GENERAL DESCRIPTION

STM 250 is a wireless magnet contact. The radio sensor is powered by a small solar cell and by that it works absolutely maintenance-free. An integrated energy store allows operation for several days even in total darkness.

The reed contact housing and the magnet housing are very small. This means that the EnOcean magnet contact is unobtrusively mountable at every window frame made of aluminum, plastic or wood.

1.1 Basic Functionality

The STM 250 supervises an integrated reed contact and reports every status change immediately (open<>closed). In addition a sign of life signal is send around every 15 minutes.



Figure 1: Wireless magnet contact STM 250

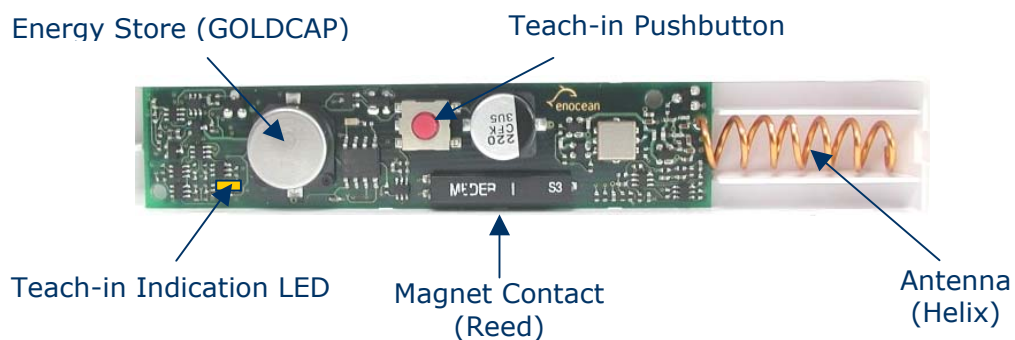


Figure 2: STM 250 PCB (open case)

1.2 Typical Applications

- **STM 250 is designed and qualified for the indoor use in building automation & installation, not for industrial applications (in cause of ESD protection)**
- **Typical applications are window, flap and door monitoring**

The STM 250 serves the 868 MHz air interface protocol of EnOcean. Together with the serial interface output of receiver device RCM 120, this product can be easily integrated into different application-specific system solutions.

The STM device is part of a powerful RF system solution from EnOcean for operation and control applications. Because the RF transmitters are self-powered (no batteries), maintenance-free RF systems can be implemented.

1.3 Features Overview

Power supply: provided by an optical cell (Solar Power Generator)

Antenna: internal helix antenna

Frequency / transmission power: 868.3 MHz / 10 mW max.

Data rate / channel bandwidth / modulation type: 120 kbps / 280 kHz / ASK

Telegram packet length (sub-telegram): 0.9 ms +/-5%

No. of (redundant) packets: 3 packets within about 40ms, delay effected at random

Transmission range: 300m free field, typ. 30m indoor

Device identifier: individual 32-bit ID factory-programmed

EnOcean telegram type: 1BS ("One Byte Sensor")

Spontaneous wake-up: 1 x internal reed contact, switch-over time \geq 80ms

Cyclic Presence signal: every 5 - 30 minutes, typ. every 15 minutes

Sleep mode current consumption: \approx 25 nA

Illumination: 200 lx up to 100000 lx

Operation startup time with empty energy store: < 10 min @ 400 lx

Illumination time for loading empty energy store to 14h operation in total darkness: \approx 5 h @ 1000 lx, \approx 13 h @ 400 lx

Illumination time for reloading energy store from device working limit to 14h operation in total darkness: < 20 min @ 400 lx, < 1 h @ 100 lx

Maximum operation time during total darkness: > 6 days ¹⁾

¹⁾ Energy store is filled up @ 400 lx to 90% of capacity

Teach-in pushbutton:on-PCB (operating at open case only)

Indicator for teach-in telegram transmission: Light Emitting Diode on the PCB
(beside teach in pushbutton)

A change of the **REED CONTACT** status or pushing the teach-in button will wake the transmitter unit to send a radio telegram immediately (reed contact position, teach-in pushbutton status, unique 32-bit sensor ID, checksum). In addition a cyclic **PRESENCE SIGNAL** is sent to announce the contact status even in case of no input signal changes (sign of life).

Between the wake-up phases, the device is in sleep mode for minimum power consumption (on average some nA only!).

1.4 Dimensions of Reed Contact Unit

Dimensions of Reed Contact Unit: base 110 x 19 mm x height 15 mm

Weight of Reed Contact Unit: 18g

Material of housing: PC/ABS

Color of housings: signal white (similar to RAL 9003)

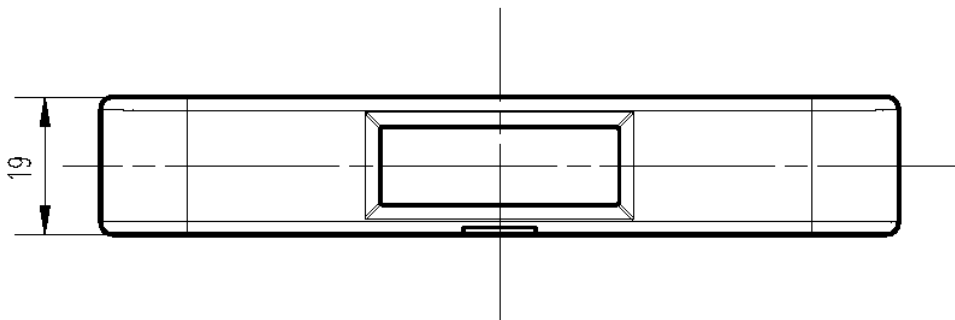


Figure 3: Top view

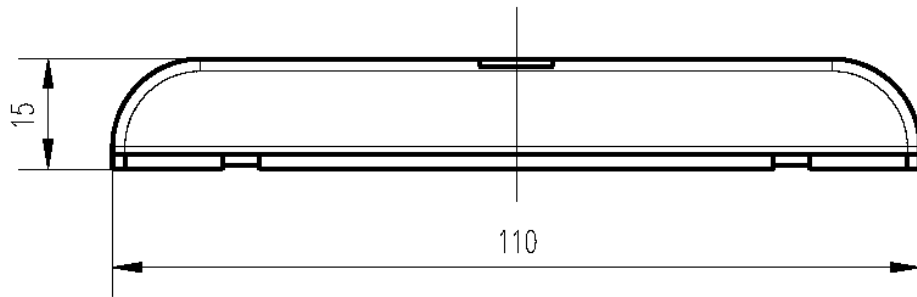


Figure 4: Side view

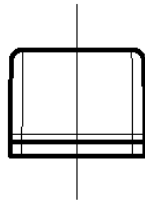


Figure 5: Front view

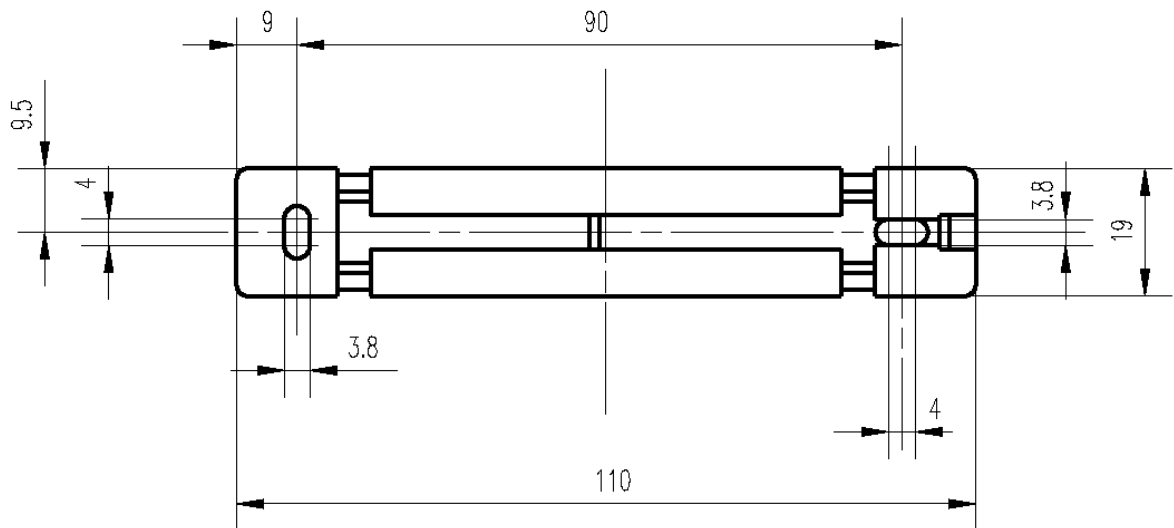


Figure 6: Bottom view

1.5 Dimensions of Magnet Housing

Dimensions of Magnet Housing: base 37 mm x 10 mm x height 5 mm

Weight of Magnet Unit: 2g

Material of housing: PC/ABS

Color of housing: signal white (similar to RAL 9003)

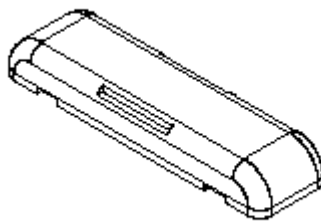


Figure 7: Magnet Housing

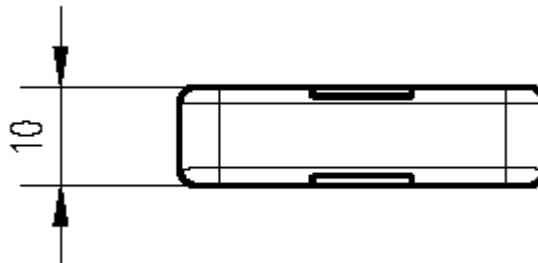


Figure 8: Top view

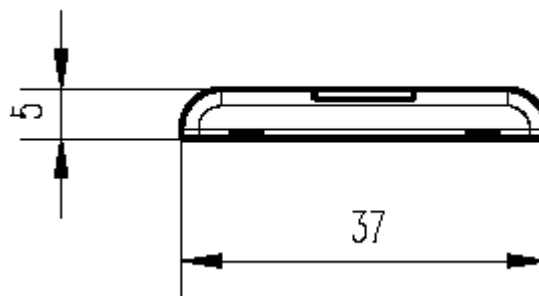


Figure 9: Side view



Figure 10: Front view

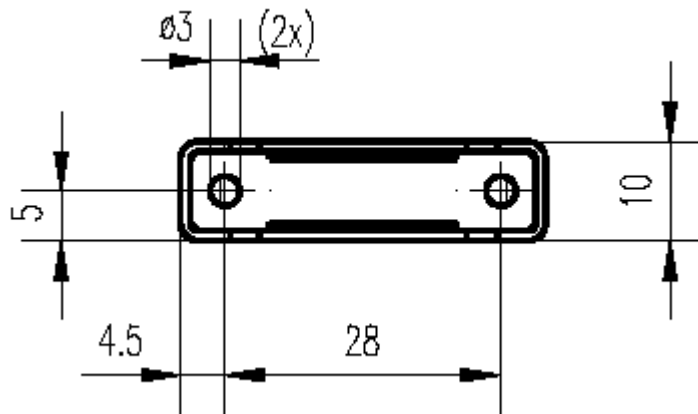


Figure 11: Bottom view

1.6 Environmental Conditions

Operating temperature: -25 up to +65 °C

Storage temperature: -25 up to +65 °C, -40 up to +85 °C for 1h max.

Humidity: 5% to 93% r.h., no condensate

Protection class: IP 40, indoor use only

1.7 Ordering Information

Type	EnOcean Ordering Code
STM 250	S3001-C250

2. FUNCTIONAL DESCRIPTION

2.1 Block Diagram

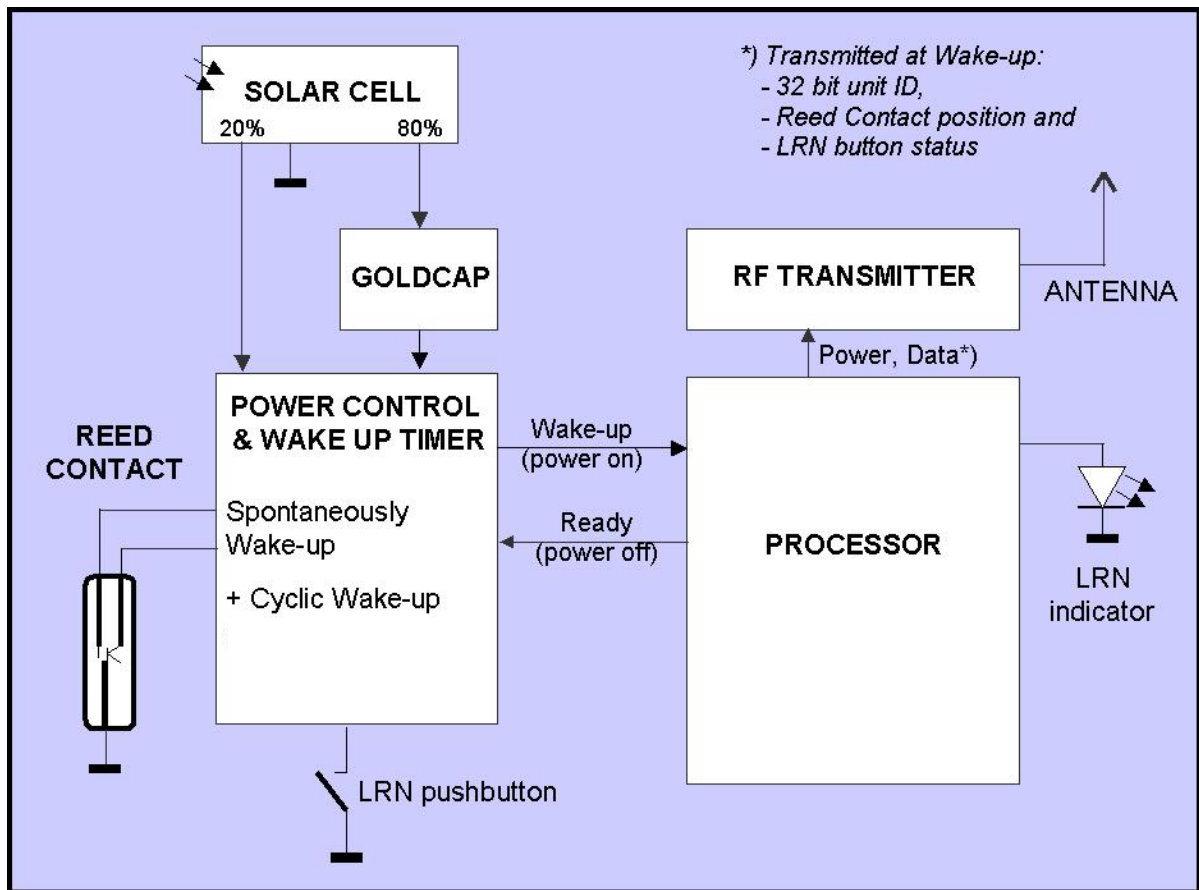


Figure 12: STM 250 block diagram

2.1.1 Device power supply: Solar cell and Goldcap energy store

The extremely powerful solar cell has been designed especially for the STM 250 for maximum unit performance at smallest dimensions. The active solar area is divided into two to provide independent device power supplies:

- a) Small active area: Main power supply
- b) Big active area: Gold Cap charging supply

2.1.2 Power control

The power control supervises supply and charging status of the energy store. It controls the power supply for wake-up timer, microprocessor and RF transmitter.

2.1.3 Wake-up timer / Reed contact / LRN pushbutton

The wake-up timer supervises status changes of the reed contact and learn pushbutton. In addition, it provides wake-up time intervals for activating the processor.

- Extremely low power consumption during sleeping time period (approx. 25nA).
- The sleep mode is terminated immediately
 1. by changing the status of the differential reed contact or
 2. when pushing the learn pushbutton.
- Cyclic processor wake-up time strongly depends e.g. on the Goldcap charging status.

2.1.4 Processor

Controls all functionalities after wake-up: First, the status of the reed contact (Open/Closed) and the LRN pushbutton are sampled. After that RF signal transmission is triggered. If the LRN pushbutton has been pressed, the output LED is activated for indicating LRN signal sending.

2.1.5 RF transmitter

The radio transmitter is powered up by the processor and sends

- 32-bit ID
- Status of the Reed Contact (open/closed)
- Status of the LRN pushbutton (pressed/released)

2.2 Solar Energy Balance Calculation

In the following diagrams, you will find the energy store operation characteristics under the condition that the **number of reed contact operations can be neglected compared to cyclic sending times of the presence signal** (normal operation in practice). Negligible implies that reed contact operations are less than 10 times a day.

Notes:

- Configuration of the Goldcap energy store: To obtain the Goldcap nominal capacity some charging/discharging cycles are needed. Because of that, the initial operating time at total darkness could be shorter as given below.
- Continuously operation at temperatures higher than 50°C could decrease the capacity of the Goldcap during lifetime. This will result in shorter charging times and shorter operating times in total darkness.

2.2.1 Initial loading time for one-night operation

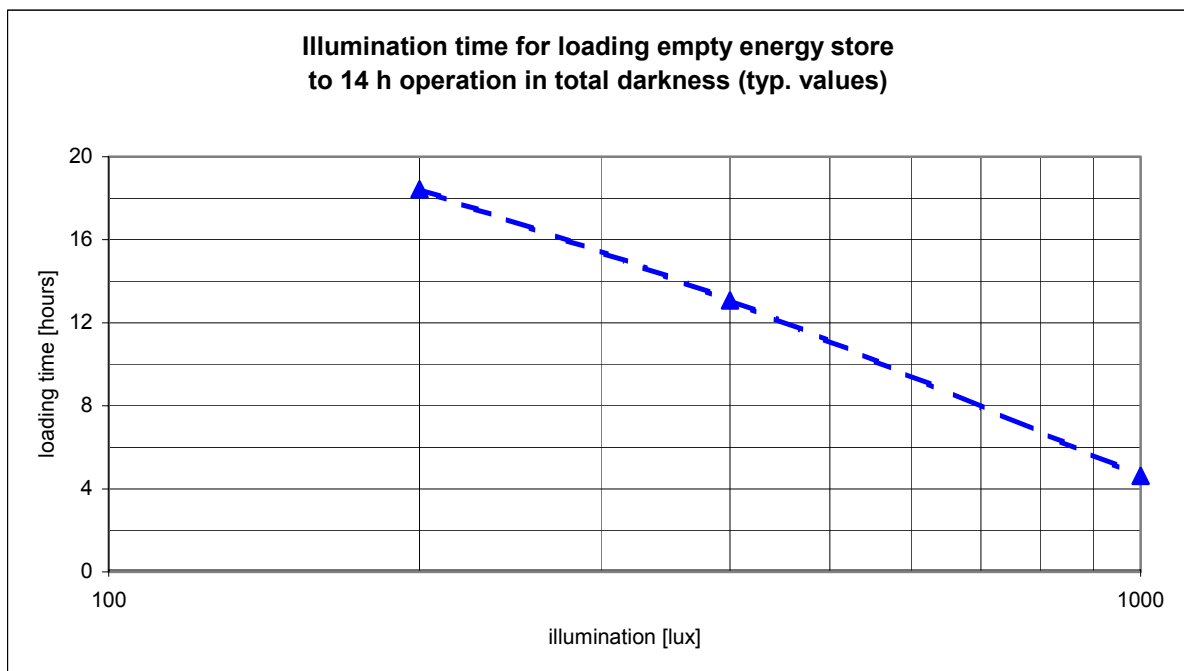


Figure 13

2.2.2 Reload time for one-night operation

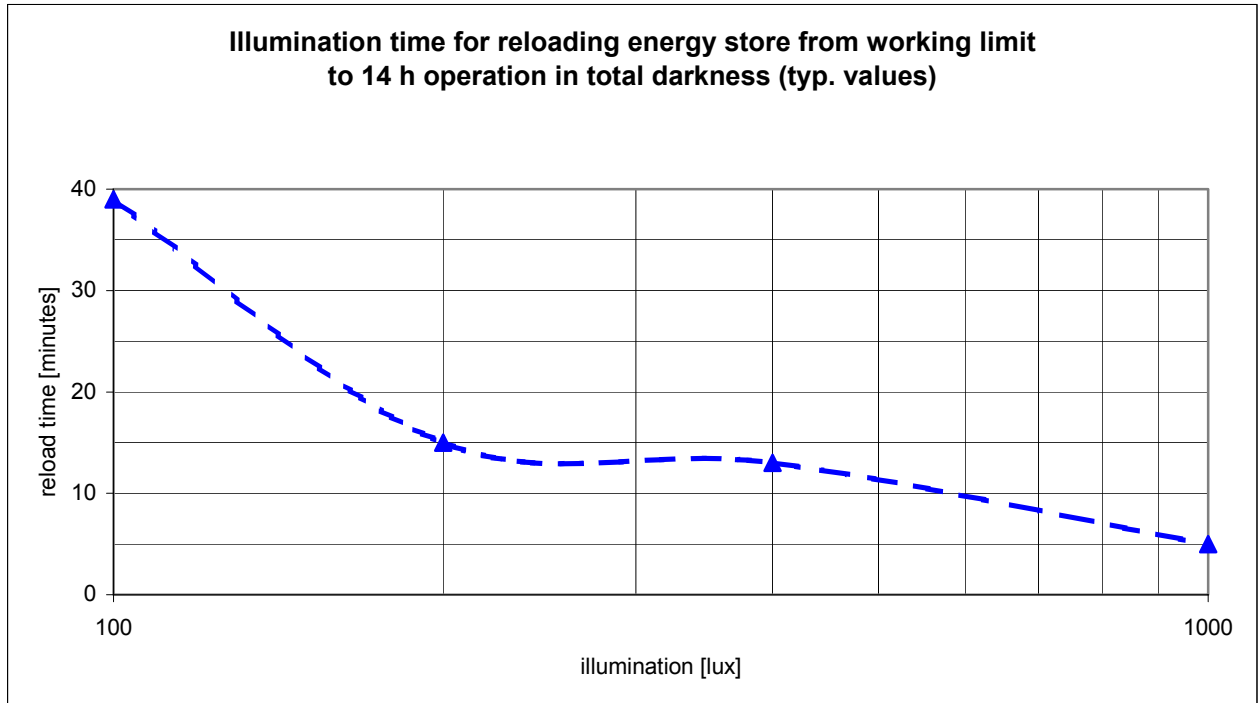


Figure 14

2.2.3 Initial load time for filling energy store to capacity

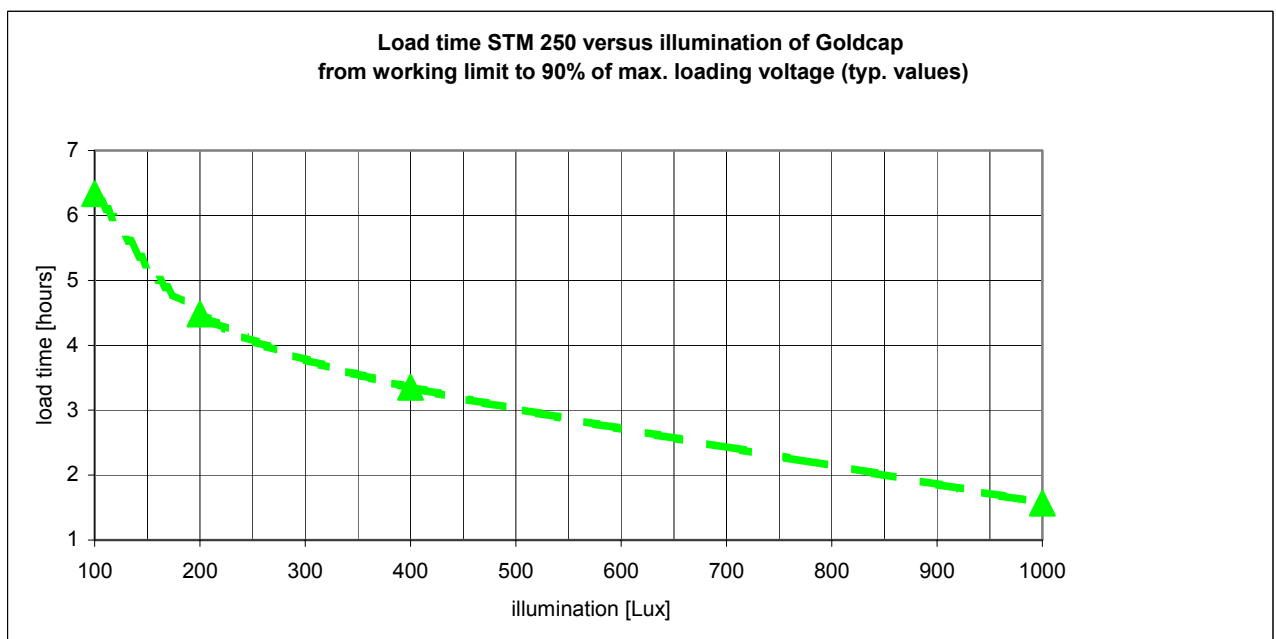


Figure 15

2.2.4 Maximum operation time in total darkness

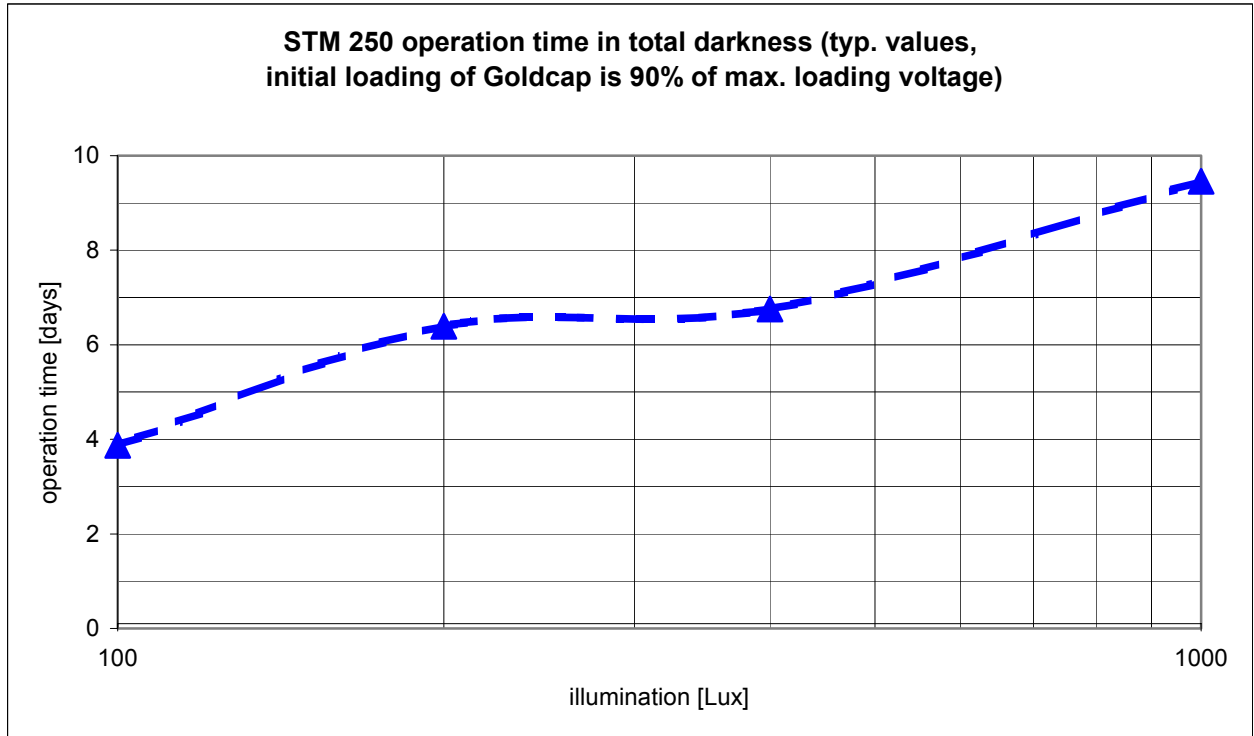


Figure 16

2.3 STM 250 Radio Telegram

For the transmission of the telemetric signals, EnOcean has defined a new dynamic radio data telegram that is adapted to the individual application. It is optimized to the essential features of energy autarkic radio sensors:

- Minimal energy demand
- Possibility of operating hundred of senders within the same radio cell
- Maximum transmission reliability
- Wide transmission range
- Easy extensibility
- Suitable for uni- and bi-directional communication
- Flexibility for adaptation of different data structures and data quantities
- Data encryption option

2.3.1 Frequency range and transmission cycle allowed

The EnOcean technology operates the 868.3 MHz radio channel (868.0 – 868.6 MHz), which is exclusively released for short-time data transmission in Europe. Timing conditions can be found in chapter 3.5 of this paper.

Because of the very low radiated field strength on average, the 868.3 MHz EnOcean radio technology can be operated in the USA and in Canada. Timing conditions can be found in chapter 3.6 of this paper.

2.3.2 Modulation process

As modulation process, EnOcean uses incoherent amplitude modulation (ASK). Digital amplitude modulation enables the implementation of very efficient energy-saving transmitters because only the "1"-bits are transferred. At the same interference signal level, the transmission security of the alternative method (FSK) is identical to that of the ASK method (Ref: Pehl, Digitale und analoge Nachrichtenübertragung, Hüthig 2001).

2.3.3 Transmission timing

The transmission timing of the radio device STM 250 has been developed to avoid possible collisions with data packages of other EnOcean transmitters as well as disturbances from the environment.

With each transmission cycle, 3 identical sub-telegrams are transmitted. The transmission of a sub-telegram lasts approximately 0.9 ms. To optimize data security, each telegram is repeated twice within about 30 ms, whereas the delay between the second and the third transmission burst is effected at random (4 time slots).

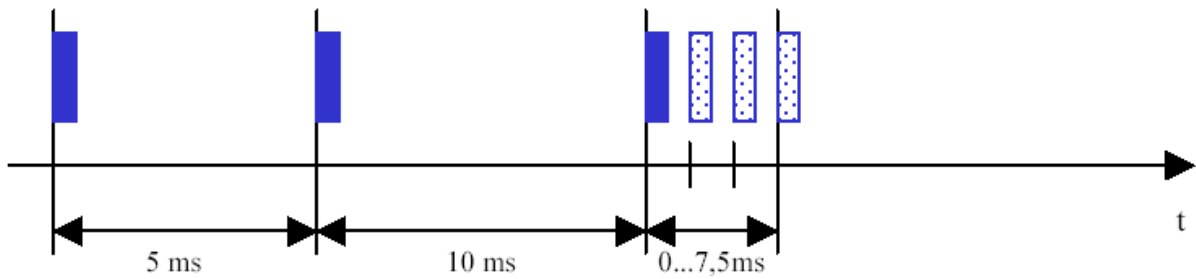


Figure 17: STM 250 radio timing ($\pm 20\%$ timer tolerance)

2.3.4 Reliable radio transmission within systems operating many sensors

The very short telegrams of EnOcean transmitters enable the operating of a large number of senders within the same radio cell; the error rate caused by telegram collisions remains extremely low. Statistically viewed, the transmission reliability is still greater than 99.99% in the case of 100 radio sensors that transmit once every minute. This means that even large office buildings and also huge industrial facilities can be equipped with a large number of sensors of this kind of radio technology.

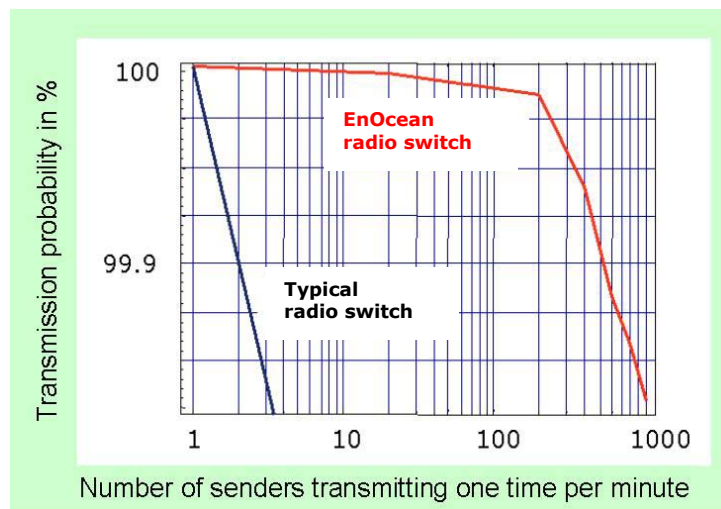


Figure 18: Transmission reliability caused by radio data collision for EnOcean light switch transmitter

2.5 Serial Data Communication via Receiver Device RCM 120

The **RCM 120 Receiver Device** of EnOcean enables standard asynchronous communication to a micro-controller or personal computer with a decompressed and simple data structure (9600 bps, 1 start bit, 8-bit data byte with LSB first, 1 stop bit).



Figure 19: Receiver device RCM 120

When the RCM 120 receiver is set to Mode 0 "Serial Interface", it transfers out data blocks of information from the received RF telegrams. For a complete transmitter message, a telegram of 14 data bytes is transferred via the serial link. The data block format is explained in detail in the RCM 110/120 User Manual.

Type of STM 250 protocol is "1BS" (One Byte Sensor):

ORG byte = 6 dec. always (EnOcean device type "1BS")

DATA_BYTE3 as follows:

Bit 7	Bit 3	Bit 0
Reserved	LEARN	STATE

Bit 0: STATE

STATE = 1: magnet present (Window CLOSED)
STATE = 0: no magnet (Window OPEN)

Bit 3: LEARN

LEARN = 1: LRN pushbutton not pressed
LEARN = 0: LRN pushbutton pressed

Bits 2..3 and Bits 4..7: reserved

DATA_BYTE2 = 0

DATA_BYTE1 = 0

DATA_BYTE0 = 0

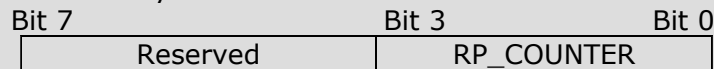
ID_BYTE3 = device identifier (Byte3)

ID_BYTE2 = device identifier (Byte2)

ID_BYTE1 = device identifier (Byte1)

ID_BYTE0 = device identifier (Byte0)

STATUS byte as follows:



Bits 0..3: RP_COUNTER

RP_COUNTER = 0: original telegram

RP_COUNTER > 0: repeated telegram

Bits 4..7: reserved

2.6 Learn Pushbutton – Learning of STM 250 to a Receiver

If necessary, the sensor radio transmitter STM 250 can be easily made known to the receiver RCM 120 – that has been set into learn mode – by simply triggering a STM 250 radio signal, for example by operating the LRN pushbutton. STM 250 devices that are currently known to the RCM 120 receiver or that are already known by the receiver are signed within H_SEQ of the serial telegram. For details, see the RCM 110/120 User Manual, but please pay attention to the following:

There are two fundamental methods for transmitter assignments to a receiver:

- 1.) Manual input of the transmitter ID into the receiver system
- 2.) The receiver system automatically learns the ID of a received radio telegram within a special Learn Mode routine.

In the second case, note that **cyclic sending sensors can be unintentionally learned**, especially if there are some sensors in operation at the same time. Because of that, it is recommended to implement a learn procedure in the system that reacts to a dedicated "Learn Telegram" only.

This special learn procedure has to be implemented by the system intelligence after RCM 120 serial interface (the RCM 120 learning procedure does not support the STM 250 Learn-Pushbutton!).

The STM 250 Learn Telegram is characterized by the unambiguously defined Bit 3 within DATA_BYTE3.

3. APPLICATIONS INFORMATION

3.1 Unit Mounting

Both the EnOcean Reed Contact as well as the EnOcean Magnet are very thin and flat. This means that the unit is unobtrusively mountable at every window or doorframe made of aluminum, plastic or wood.

Mounting position of the Reed Contact is horizontal, vertically or even tilted. The arrow signs on the base of the Reed Contact should be directed downwards. In this mounting position, the STM 250 housing offers protection against splashing water drops.

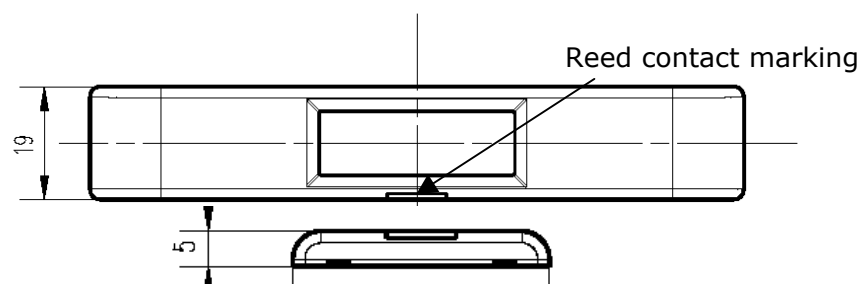
Recommendation for mounting the STM250 on metal surfaces or window frames of aluminum:

Please note that a radio receiver unit (e.g. RCM 120) should not be mounted in the same plane than the STM 250 base plate is mounted, because in extension of the metal surface the transmission range is reduced by physical radio transmission effects of the antenna near to metal. For example the receiver should not be mounted at the window front side.

First time operation of the LRN pushbutton: Please note that the PCB is varnished for improved humidity protection. It's possible that first time operation of the pushbutton can require some increased finger pressure. This behavior is due to fabrication process and is no malfunction.

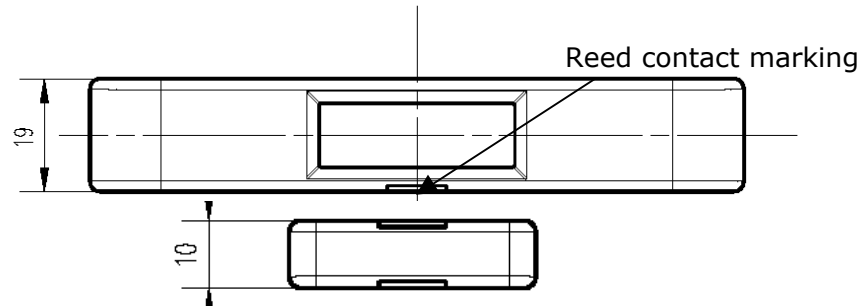
3.2 Recommendations for Magnet Positioning

The flat magnet should be positioned by facing the housing in the middle of the reed contact marking as follows:



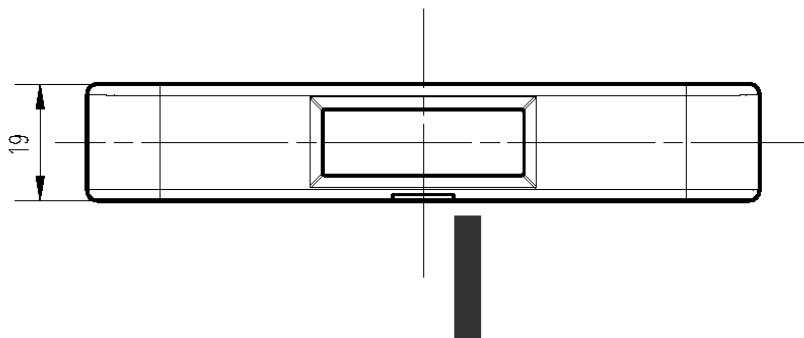
**Figure 20: Righted positioning of the Magnet
(Typical for window mounting)**

The magnet can be positioned in vertical or in horizontal position to the Reed Contact housing. The distance between housing and magnet should be less than 5 mm.

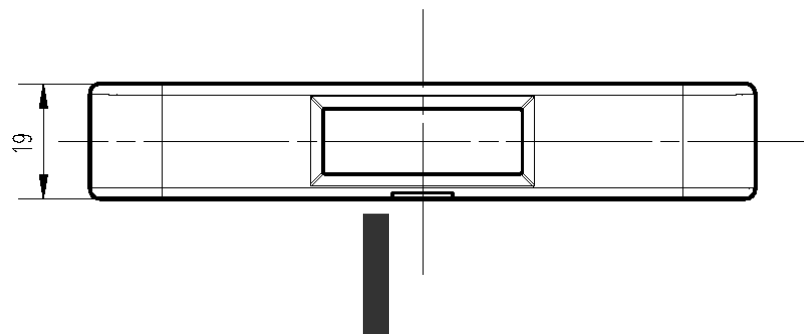


**Figure 21: Planar positioning of the Magnet
(Typical for door mounting)**

The round-pole magnet can be removed from the magnet housing. This enables smart embedding into wooden window casements in square position to the Reed Contact housing. But note that the round-pole must be mounted **beside** the reed contact marking, as follows:



or:



**Figure 22: Pole-faced positioning of Magnet
(Typical for mounting at wooden window casements)**

The distance between housing and magnet should be less than 4 mm when using this mounting position.

Attention: Always take care for sufficient distance of the magnet to magnetic data carriers, e.g. credit cards. Data could be erased !

3.3 Transmission Range

The main factors that influence the system transmission range are type and location of the antennas of the receiver and the transmitter, type of terrain and degree of obstruction of the link path, sources of interference affecting the receiver, and “dead” spots caused by signal reflections from nearby conductive objects. Since the expected transmission range strongly depends on this system conditions, range tests should categorically be performed before notification of a particular range that will be attainable by a particular application.

The following figures for expected transmission range are considered by using a PTM, a STM or a TCM radio transmitter device and the RCM or the TCM radio receiver device with preinstalled whip antenna and may be used as a rough guide only:

- **Line-of-sight connections:** Typically 30m range in corridors, up to 100m in halls
- **Plasterboard walls / dry wood:** Typically 30m range, through max. 5 walls
- **Brick walls / aerated concrete:** Typically 20m range, through max. 3 walls
- **Ferroconcrete walls / ceilings:** Typically 10m range, through max. 1 ceiling
- **Fire-safety walls, elevator shafts, staircases and supply areas should be considered as screening.**

The angle at which the transmitted signal hits the wall is very important. The effective wall thickness – and with it the signal attenuation – varies according to this angle. Signals should be transmitted as directly as possible through the wall. Wall niches should be avoided. Other factors restricting transmission range:

- **Magnet contact mounted on metal surfaces: Please don't mount the receiver at the window front side because there is a clear loss of transmission range in plane direction of the metal window frame (radio characteristic)!**
- **Hollow lightweight walls filled with insulating wool on metal foil**
- **False ceilings with panels of metal or carbon fiber**
- **Lead glass or glass with metal coating, steel furniture**

The distance between EnOcean receivers and other transmitting devices such as computers, audio and video equipment that also emit high-frequency signals should be at least 0.5m

Please note for use in the US and in Canada: In the US, 868 MHz frequency range is used by Trunk Radio. Since a reduction of transmission range is to be expected near a trunk radio station, range tests at the system's target location should categorically be performed before notification of a particular range in the US and in Canada!

3.4 CE Approval Requirements

The devices bear the EC conformity marking CE and conform to the R&TTE EU-directive on radio equipment. The assembly conforms to the European and national requirements of electromagnetic compatibility. The conformity has been proven and the according documentation has been deposited at EnOcean. The devices can be operated without notification and free of charge in the area of the European Union, in Switzerland, in Croatia, in

Cyprus, in Czech, in Estonia, in Hungary, in Latvia, in Lithuania, in Malta, in Poland, in Romania and in Slovenia. The following provisos apply:

- EnOcean RF devices must not be modified or used outside their specification limits.
- EnOcean RF devices may only be used to transfer digital or digitized data. Analog speech and/or music are not permitted.
- EnOcean RF devices must not be used with gain antennas, since this may result in allowed ERP or spurious emission levels being exceeded.
- The final product incorporating EnOcean RF devices must itself meet the essential requirement of the R&TTE Directive and a CE marking must be affixed on the final product and on the sales packaging each. Operating instructions containing a Declaration of Conformity has to be attached.
- If the STM 250 transmitter is used according to the regulations of the 868.3 MHz band, a so-called "Duty Cycle" of 1% per hour must not be exceeded. Permanent transmitters such as radio earphones are not allowed. For approval aspects, it must be ensured that the **STM 250 reed contact is not operated more than 13.000 times per hour** (e.g. window opened or window closed). For this calculation the extraordinary short telegram length is considered including all subtelegrams (see Chapter 2.3.3). Also a tolerance of 5% in telegram length is included.

3.5 FCC/IC Approval Requirements

This device complies with Part 15 of the FCC Rules and with RSS-210 of Industry Canada. If this device is operated in compliance with the following requirements it can be operated without notification and free of charge in the area of the United States of America and in Canada. Operation is subject to the following two conditions:

- (1) this device may not cause harmful interference, and
- (2) this device must accept any interference received, including interference that may cause undesired operation.

Trade Name: STM 250
Model No: STM 250



FCC ID: SZV-STM250
IC: 5713A-STM250

This device complies with Part 15 of the FCC Rules and with RSS-210 of Industry Canada. Operation is subject to the following two conditions. (1) this device may not cause harmful interference, and (2) this device must accept any interference received, including interference that may cause undesired operation.

Warning: Changes or modifications made to this equipment not expressly approved by EnOcean may void the FCC authorization to operate this equipment.

This equipment has been tested and found to comply with the limits for a Class B digital device, pursuant to Part 15 of the FCC Rules. These limits are designed to provide reasonable protection against harmful interference in a residential installation.



This equipment generates, uses and can radiate radio frequency energy and, if not installed and used in accordance with the instructions, may cause harmful interference to radio communications.

However, there is no guarantee that interference will not occur in a particular installation. If this equipment does cause harmful interference to radio or television reception, which can be determined by turning the equipment off and on, the user is encouraged to try to correct the interference by one or more of the following measures:

- Reorient or relocate the receiving antenna.
- Increase the separation between the equipment and receiver.
- Connect the equipment into an outlet on a circuit different from that to which the receiver is connected.
- Consult the dealer or an experienced radio/TV technician for help.

Due to FCC 15.231 operational and timing requirements, **the STM 250 magnet contact must not be operated more than 1414 times per hour** (opened or closed):

- Total duration of transmissions must not exceed more than two seconds per hour
- STM250 packet length is 0.9 ms, 3 redundant packets, tolerance of 5% in packet length, 50% on average packet Ton/Toff ratio

ATTENTION: Please be aware of the possibility of reduced transmission range when using EnOcean 868 MHz system near a US trunk radio station!

4. TOOLS

4.1 Evaluation Kit EVA 100/105

EVA 100 is an evaluation kit to support a simple setting-up operation of the receiver side when the EnOcean sensor transmitter device STM 250 is evaluated. EVA 100 supports a rapid evaluation of the RCM 120 serial receiver mode (e.g. via PC monitor) and supports the fast development of applications.



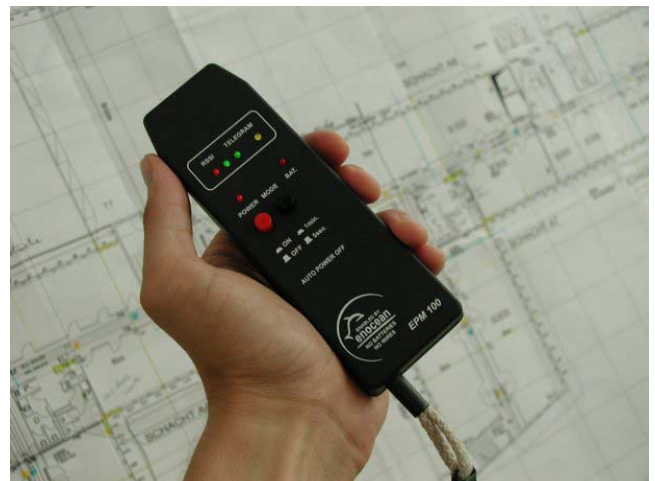
Type	EnOcean Ordering Code	Scope of supply
EVA 100	H3004-G100	<ul style="list-style-type: none"> Evaluation board EVA-PCB EnOcean radio devices STM 100, PTM 100, RCM 110 and RCM 120 CD with RS232 PC-link monitor software and detailed kit documentation 230V wall power supply for EVA-PCB Convenient equipment case
EVA 105	H3004-G105	<ul style="list-style-type: none"> US version (110V wall power supply)

4.2 Field Intensity Meter EPM 100

The EPM100 is a mobile field-intensity meter that helps the engineer to find the best installation positions for sensor and receiver. It can also be used to check disturbances in links to already installed equipment. The EPM100 displays the field intensity of received radio telegrams and interfering radio signals in the 868MHz range.

The simplest procedure for determining the best installation positions for the radio sensor/receiver:

- Person 1 operates the radio sensor and generates pushbutton radio telegrams.
- Person 2 checks the received field intensity on the meter display to find the optimal installation position.



5. DECLARATION OF CONFORMITY



EnOcean GmbH
Kolpingring 18a
D 82041 Oberhaching
www.enocean.com

Declaration of Conformity



We: EnOcean GmbH
Kolpingring 18a
D 82041 Oberhaching
Germany

Declare: under our sole responsibility that the following labeled products:

Transmitter: PTM100, STM100, STM250, PTM200

Receiver: RCM110, RCM120, RCM121

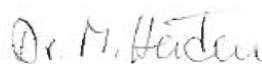
Transceiver: TCM110, TCM120

to which this declaration relates, are, when used according to specification, in conformity with the technical requirements of the standards and the provisions of the essential requirements of the Directives detailed below.

Directives: Electromagnetic Compatibility Directive 89/336/EC
Radio and Telecommunications Terminal Equipment Directive R&TTE 1999/5/EC

Standards: ETSI EN 301 489-1: 2001-09, ETSI EN 301 489-3: 2001-11 (class 2)
ETSI EN 61000-6-2: 2002-08
ETSI EN 300 220-3: 2000-09

Place of issue: Oberhaching
Quality Manager:
Dr. Matthias Heiden
Signature:



Date of issue: 13. May 2005
General Manager:
Markus Brehler
Signature:

